

HA 16 PX HA 18 PX



- Max. 34 ft 9 in (10.60 m) horizontal outreach (HA18PX).
- 50% gradeability.
- 16 in (40 cm) ground clearance.
- Standard 4 wheel drive and steer.
- Soft, proportional and simultaneous movements.

ISO 9001
GROUP
PINGUELY
HAULOTTE



ARTICULATED BOOMS



VERTICAL MASTS



TELESCOPIC BOOMS



SCISSOR LIFTS



TRAILERS

Haulotte®

ON THE UP

HA 16 PX HA 18 PX

Articulated boom

The Haulotte® advantages

- 52 ft and 57 ft (16 and 18 m) working heights
- Hydraulic differential lock and 16 in (40 cm) ground clearance for improved rough terrain capability
- Gradeability up to 50%
- Continuous 360° turntable rotation
- 45 sec. lift speed to full height
- Full proportional controls and simultaneous boom functions improve productivity
- Load control in cage
- Improved working area through a positive / negative articulating fly jib with 140° movement
- Zero tailswing
- 180° hydraulic platform rotation
- Improved design for travel / transport (HA 16 PX: 5.25 m / 17 ft 3 in transport length)
- Robust, reliable and easy to maintain design
- Improved safety due to load limiter in the basket

STANDARD FEATURES

- 4 wheel drive and steer
- Swing out engine tray for easier maintenance
- 72 l (16 gal) fuel tank; 1.50 m filling height
- 5° tilt alarm
- 12 V battery / electrical control system
- Battery electric emergency control in cage
- Free wheeling device
- Hourmeter
- Slewing block pin
- Towing hooks / lifting eyes

OPTIONS & ACCESSORIES

- Dual Gas / Fuel engine (GM 1.6 L / 23 kW)
- 3.3 kW on-board generator
- 230 V / 115 V - 16 A power line in cage
- Large basket 91 x 32 in (2.3 x 0.80 m)
- Travel alarm
- Rotating beacon
- Working light
- Catalytic exhaust
- Encoded starting device
- Biodegradable hydraulic oil
- Cold countries kit
- Hot countries kit
- Sand tyres
- Road tyres

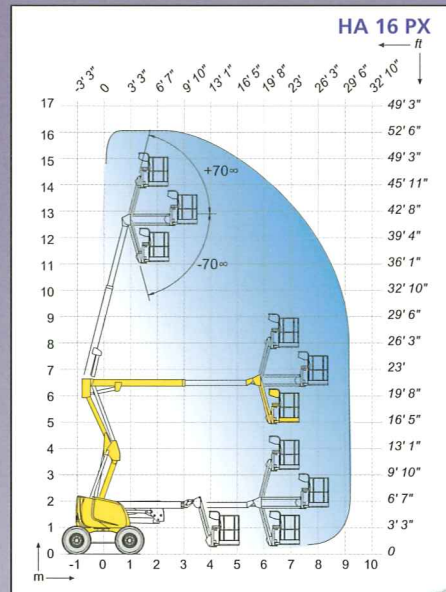
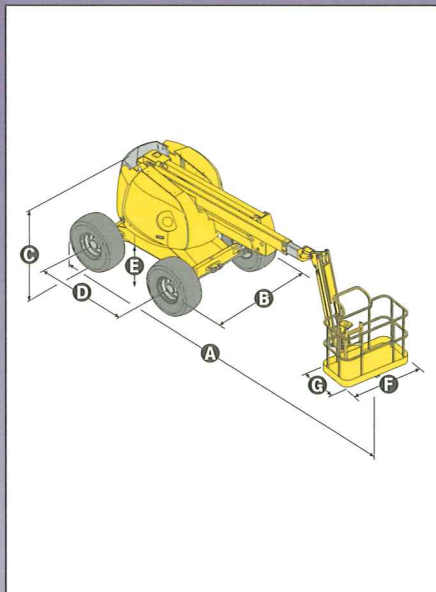

SPECIFICATIONS

	HA 16 PX		HA 18 PX	
Working height	16.0 m	52 ft	17.3 m	56 ft 2 in
Platform height	14.0 m	46 ft	15.3 m	50 ft 2 in
Maximum outreach	9.1 m	29 ft 10 in	10.60 m	34 ft 9 in
Up and over clearance	6.60 m / 21 ft 8 in			
Platform capacity	230 kg / 507 lb			
Fly jib range of motion	140° (+70° / -70°)			
A Stowed length	6.95 m	22 ft 10 in	7.60 m	25 ft
B Width	2.30 m / 7 ft 6 in			
C Stowed height	2.20 m / 7 ft 3 in			
D Wheelbase	2.0 m / 6 ft 7 in			
E Ground clearance	40 cm / 16 in			
F x G platform size	1.8 m x 0.8 m / 71 in x 32 in			
Travel / transport length	5.25 m	17 ft 3 in	5.90 m	19 ft 4 in
Travel / transport height	2.20 m / 7 ft 3 in			
Tailswing	0			
Drive speed	1.5 / 5.5 km/h		0.9 / 3.4 mph	
Outside turning radius	4 m / 13 ft 1 in			
Inside turning radius	1.9 m / 6 ft 3 in			
Turntable rotation (continuous)	360°			
Hydraulic platform rotation	180°			
Engine	Deutz Diesel 38 CV (38 HP) – 28 kW			
Gradeability	50%			
Tyres (foam filled)	385/65-22.5			
Hydraulic tank	100 l / 22 gal			
Fuel tank	72 l / 16 gal			
Weight	7,100 kg	15,653 lb	8,120 kg	17,900 lb



D I S T R I B U T E D B Y



Haulotte®